

1. Prepare door panels.

If your door hasn't been prepared for the ActaLink join, follow the machining instructions below:

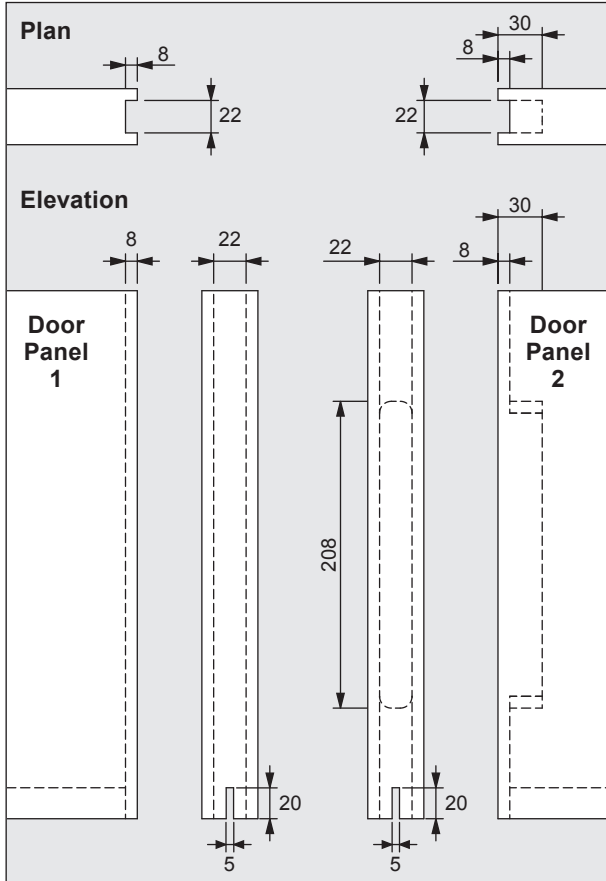

Rebates must match each other over the full length of the door.

2. Fit aluminium channel.

Fix aluminium channel (A) to Door Panel 1 with the #8x38mm screws provided at equal distances (approximately 300mm intervals) to the door.



3. Fit magnet.

Fit the magnet plate (B) to the aluminium channel in Door Panel 1 with the 2 x #10x63mm screws provided.



4. Fit plate.

Fit the brass coloured armature plate (C) to Door Panel 2 with the 4 x #8x50mm screws provided.

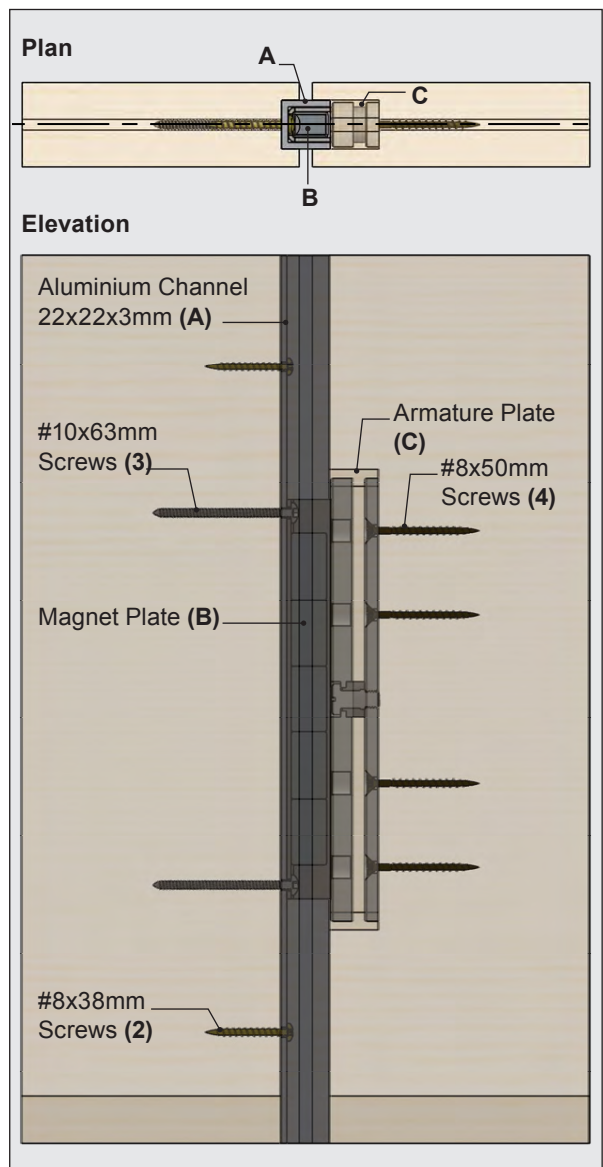
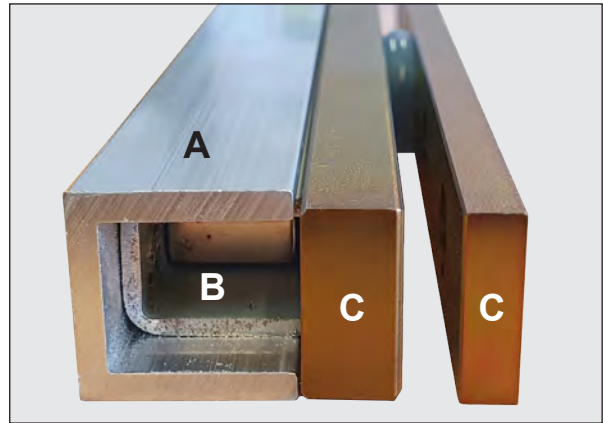
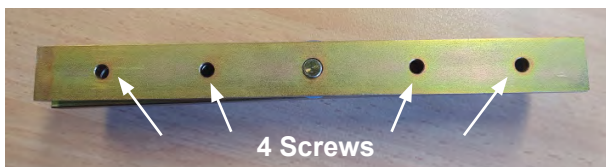

5. Hang Doors.

Hang the door panels and adjust the door heights so both panels are aligned.

Join the doors by pushing them together.

© All copyright and other property in this document is reserved by Cavity Sliders Limited. Details and specifications are subject to change without notice. Whilst all care is taken to ensure the accuracy of all information, no responsibility will be accepted for any errors or omissions. Drawings are not to scale. All dimensions in mm unless otherwise specified. NZ Patent No. 533838; Aust Patent No. 2005202818